

BM6E

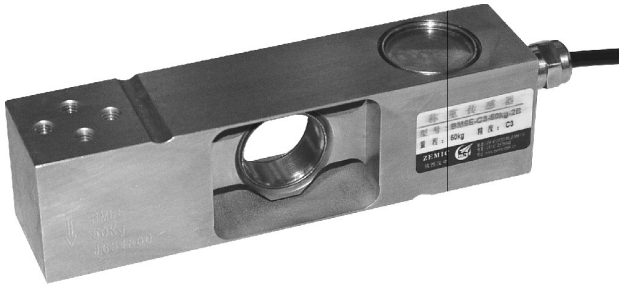

- BM6E load cells are available in the capacities 50kg~300kg.
- Stainless steel construction, hermetically welded oil proof, waterproof, anti-corrosive gas and medium making it suitable for all kinds of environments.
- Single point with parallel beam, suitable for electronic scales, platform scales, belt scales and other electronic weighing devices.
- Recommended platform size: 600×600mm

Features

- Capacity: 50kg~300kg
- High accuracy
- Stainless steel construction
- Low profile and easy installation



Specifications			
Capacity	kg	50/200/300	
Accuracy		C2	C3
Maximum number of verification intervals	n _{max}	2000	3000
Minimum load cell verification interval	v _{min}	E _{max} /5000	E _{max} /10000
Combined error	(%FS)	≤ ±0.030	≤ ±0.020
Creep	(%FS/30min)	≤ ±0.024	≤ ±0.016
Temperature effect on sensitivity	(%FS/10°C)	≤ ±0.017	≤ ±0.011
Temperature effect on zero	(%FS/10°C)	≤ ±0.023	≤ ±0.015
Output sensitivity	(mv/v)	2.0 ± 0.2/2.0 ± 0.002	
Input resistance	(Ω)	350 ± 3.5	
Output resistance	(Ω)	351 ± 2.0	
Insulation resistance	(MΩ)	≥ 5000(50VDC)	
Zero balance	(%FS)	1.5	
Temperature, compensated	(°C)	-10 ~ +40	
Temperature, operating	(°C)	-35 ~ +65	
Excitation, recommended	(V)	5 ~ 12(DC)	
Excitation, max	(V)	18(DC)	
Safe overload	(%FS)	150	
Ultimate overload	(%FS)	300	
Corner correction		0.02%load value/100mm	

Note: output sensitivity of S1 type is 2.0 ± 0.002mv/v

Outline Dimension mm(inch)

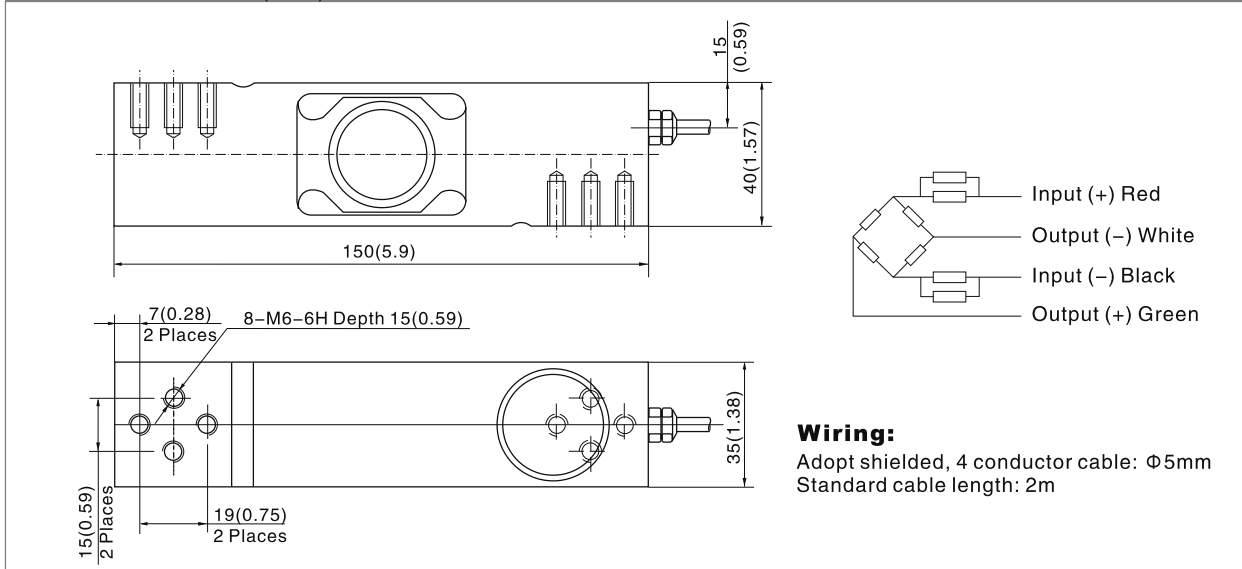

Wiring:

Adopt shielded, 4 conductor cable: Φ5mm
Standard cable length: 2m