

- L6Q load cells are available in the capacities 50kg~250kg.
- Aluminum construction with parallel beam.
- Silicon adhesive sealed, stainless steel cover, surface anodized and anti-corrosion.
- Integral structure and easy installation.
- Suitable for electronic pricing scales, platform scales and other electronic weighing devices.

Features

- Capacity: 50kg~250kg
- High accuracy
- Max. platform size: 400×400mm
- PTB Approval No: D09-07.06



Specifications				
Capacity	kg	50/100/150/200/250		
Accuracy		C3D	C3	C3G
Approvals			OIML R60 C3	
Maximum number of verification intervals	n _{max}	2500	3000	4000
Minimum load cell verification interval	v _{min}	E _{max} /5000	E _{max} /7000	E _{max} /11000
Combined error	(%FS)	≤ ±0.030	≤ ±0.020	≤ ±0.015
Creep	(%FS/30min)	≤ ±0.020	≤ ±0.0167	≤ ±0.0125
Temperature effect on sensitivity	(%FS/10°C)	≤ ±0.021	≤ ±0.0175	≤ ±0.0131
Temperature effect on zero	(%FS/10°C)	≤ ±0.028	≤ ±0.020	≤ ±0.0127
Output sensitivity	(mv/v)	2.0±0.2		
Input resistance	(Ω)	406±6		
Output resistance	(Ω)	350±3		
Insulation resistance	(MΩ)	≥5000(50VDC)		
Zero balance	(%FS)	2		
Temperature, compensated	(°C)	-10~+40		
Temperature, operating	(°C)	-35~+65		
Excitation, recommended	(V)	5~12(DC)		
Excitation, max	(V)	18(DC)		
Safe overload	(%FS)	150		
Ultimate overload	(%FS)	300		
Corner correction		0.02%load value/100mm		

Outline Dimension mm(inch)

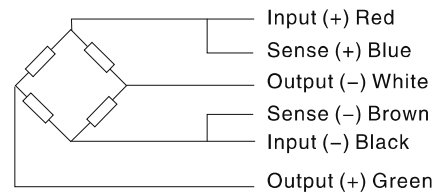
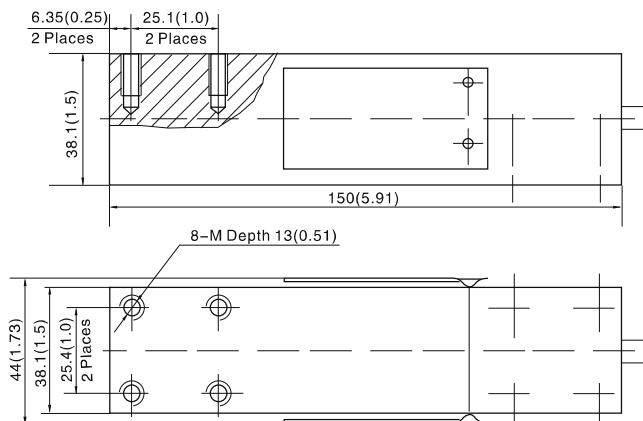

Wiring:

Adopt a shielded, 6 conductor cable, and cable jacket is PVC.
Cable length: 3.0 ± 0.05m
Cable diameter: 5.0 ± 0.2mm

M	Metric	Imperial
	M6	1/4-20UNC