

# HM2D4



- HM2D4 load cells are available for manifold accurate measurement in the capacities 0.5t~20t.
- Alloy steel, completely welded, oil-proof, waterproof and anti-corrosive gas and medium, suitable for all kinds of environments.
- Spoke type, suitable for electronic truck scales, hopper scales, automotive testing equipments, and other electronic weighing or force measuring fields.

### Features

- Capacity: 0.5t~20t
- High accuracy
- Alloy steel construction
- Low profile



### Specifications

Capacity	t	0.5/1/2/5/10/20		
Accuracy		G1	C1	C2
Maximum number of verification intervals	n <sub>max</sub>	1000	1000	2000
Minimum load cell verification interval	v <sub>min</sub>	E <sub>max</sub> /2000	E <sub>max</sub> /3000	E <sub>max</sub> /5000
Combined error	(%FS)	≤ ±0.050	≤ ±0.050	≤ ±0.030
Creep	(%FS/30min)	≤ ±0.050	≤ ±0.038	≤ ±0.024
Temperature effect on sensitivity	(%FS/10°C)	≤ ±0.050	≤ ±0.028	≤ ±0.017
Temperature effect on zero	(%FS/10°C)	≤ ±0.050	≤ ±0.047	≤ ±0.023
Output sensitivity	(mv/v)	2.0±0.002		
Input resistance	(Ω)	350±3		
Output resistance	(Ω)	351±2		
Insulation resistance	(MΩ)	≥5000(50VDC)		
Zero balance	(%FS)	1.0		
Temperature, compensated	(°C)	-10~+40		
Temperature, operating	(°C)	-35~+65		
Excitation, recommended	(V)	5~12(DC)		
Excitation, max	(V)	18(DC)		
Safe overload	(%FS)	150		
Ultimate overload	(%FS)	300		

### Outline Dimension mm(inch)

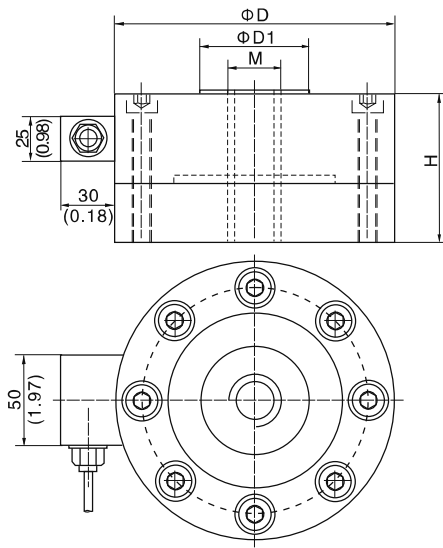

Capacity(t)	Dimension (mm)	ΦD	ΦD1	H	M
0.5t ~ 2t		105 (4.13)	28 (1.10)	70 (2.76)	M14 × 2
5t		120 (4.72)	33 (1.3)	80 (3.15)	M20 × 1.5
10t, 20t		155 (6.10)	60.5 (2.38)	90 (3.54)	M32 × 2

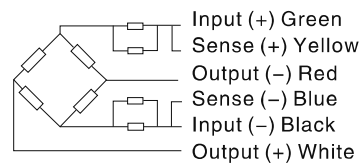

### Wiring:

Adopt shielded, 6 conductor cable: Φ5.6mm  
Standard cable length: 5m